

TOSHIBA

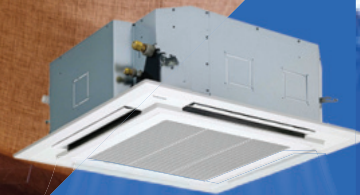

The **Premier** Choice for
Trustworthy Cooling Comfort

Toshiba SPI PREMIER







Introducing Toshiba SPI Premier

Designed, developed and engineered for Indian conditions, Toshiba SPI Premier delivers the ultimate in cooling comfort, efficiency and sustainability. This unique product is built with a host of advantages that makes it the clear, premier choice for trustworthy cooling.



Highest capacity offering of 7 HP



Packed with PM 2.5 filter



High-energy performance with BEE 5-star rating



Aesthetic cooling solution



Reduced contamination with acrylic resin coating & sealed-up inverter box



Suitable for use in high-end residential & commercial spaces





The **premier** choice
for **Eco-Friendliness**

The new-generation, Toshiba SPI Premier HVAC solution is engineered to not only give ultimate cooling comfort to users, but to do so with a significantly reduced impact on global warming. It delivers unparalleled environment-friendly advantages by using a lower GWP refrigerant and by enabling a high ISEER value in its functionality.

► **R32 refrigerant**

Owing to the low R32 GWP refrigerant used, Toshiba SPI Premier has a minimized impact on the climate. This, combined with a 36% reduction of refrigerant charge, decreases the total equivalent CO₂ by **79.4%**.

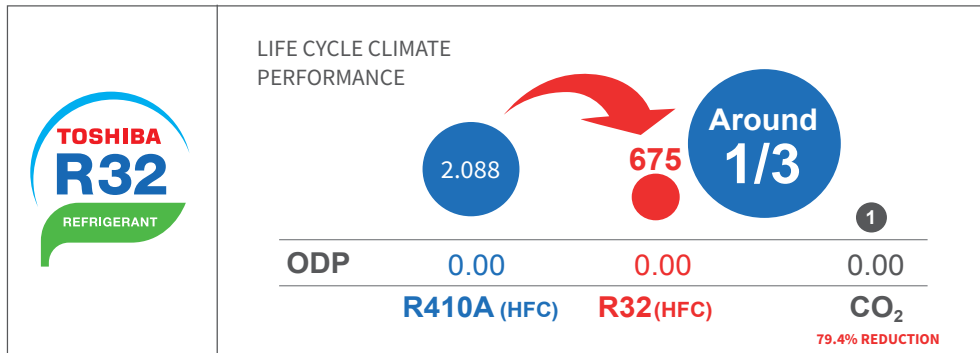

► **ISEER value**

Toshiba SPI Premier is designed to consume less power thus giving it a high ISEER value and optimal energy consumption.

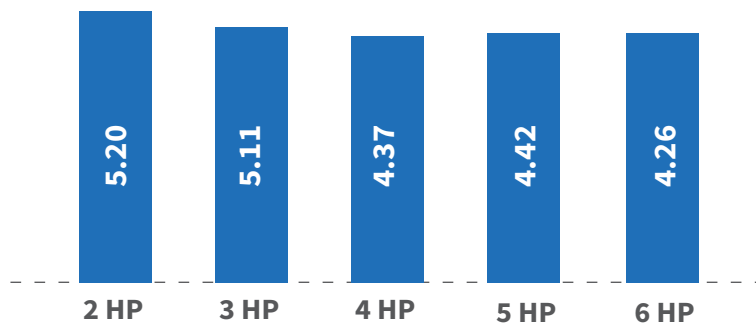

Performance and efficiency are two key factors that make for a good HVAC unit. The **7 HP** Toshiba SPI Premier is built with exceptional features that ensure effective cooling and expert performance.

► **BEE 5-star rating**

The high-performance cooling unit has achieved a 5-star BEE rating, the highest level awarded. This is due to an unmatched expertise involved in making Toshiba SPI Premier a powerful yet energy-efficient cooling system.



► **7 HP capacity**

Toshiba SPI Premier is the only product to have a substantial cooling capacity of 7 HP. It delivers superior cooling efficiencies and long-lasting performance in the entire space it is installed in.



7 HP





The **premier** choice
for **Performance & Efficiency**



The **premier** choice
for **Cleaner Air**



An HVAC unit defines the quality of air in the room, and this is a responsibility that Toshiba understands well. To prevent dust and other contaminants from clogging the unit which would ultimately lead to mould formation and a foul smell, Toshiba SPI Premier has a unique clean-air solution made possible by its PM 2.5 filter and acrylic resin.

► PM 2.5 filter

Engineered to filter out airborne particles less than 2.5 microns, the in-built PM 2.5 filter offers a unique advantage in enabling exceptionally clean air in spaces.

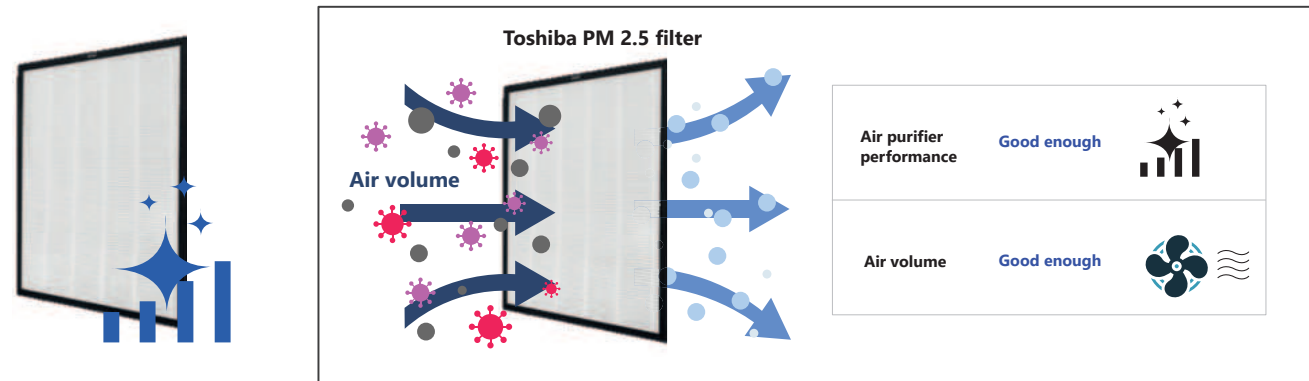

► Acrylic resin

The acrylic resin coating prevents dirt and oil from sticking to the fins of the FCU heat exchanger, and the dew condensation water then flushes out the dirt and oil. This self-clean mechanism inhibits the propagation of mould after washing.

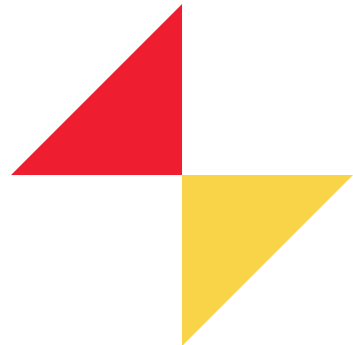
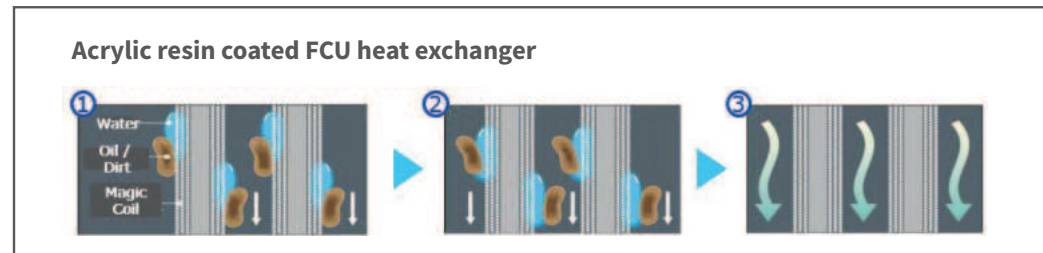



The **premier** choice
for **Aesthetics**



Toshiba SPI Premier not only delivers superior cooling for your absolute comfort, but is also specially designed to look classy and seamlessly blend into your spaces.

▶ **Compact size**

This exceptional HVAC solution is crafted with an aluminium alloy heat exchanger. Aluminium, as a material, is one-third the weight of copper. This allows our HVAC solution to realize a lighter weight CDU.

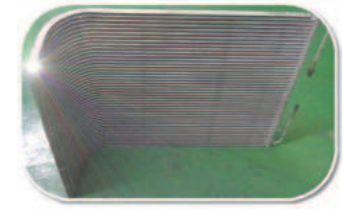

Heat exchanger

▶ **Aesthetic 4-way cassette**

Toshiba SPI Premier is built to impress. The aesthetic 4-way indoor unit supports new panel designs that have been perfected to meet your specific requirements. Now, you can welcome an HVAC solution that enhances the aesthetics of your space.



▶ **Choice of controller**

Offered as an optional accessory with the HVAC unit, get wired remote controllers for your ease of operation.



RBC-ASCU11-E



RBC-AMTU31-E



RBC-AMSU51-EN

Users can also select from other Toshiba wired remote controls. Please connect with your Toshiba sales representative for more details.



The **premier** choice
for **Comfort & Convenience**

Toshiba SPI Premier is specially crafted to bring comfort and convenience in your cooling requirements. Equipped with a 5-step airflow and an auto restart function, it delivers accuracy in airflow adjustment while effectively combating issues of unstable electricity and blackouts.

► 5-step airflow

The wind strength can be controlled with higher accuracy*.

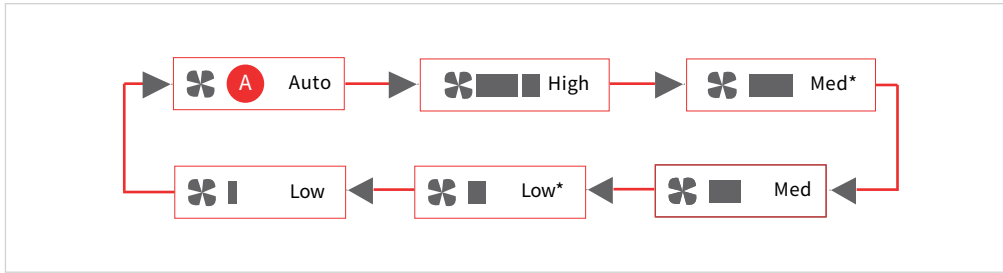

*This function is available with a wired remote controller named RBC-ASCU11-E.

► Auto restart function

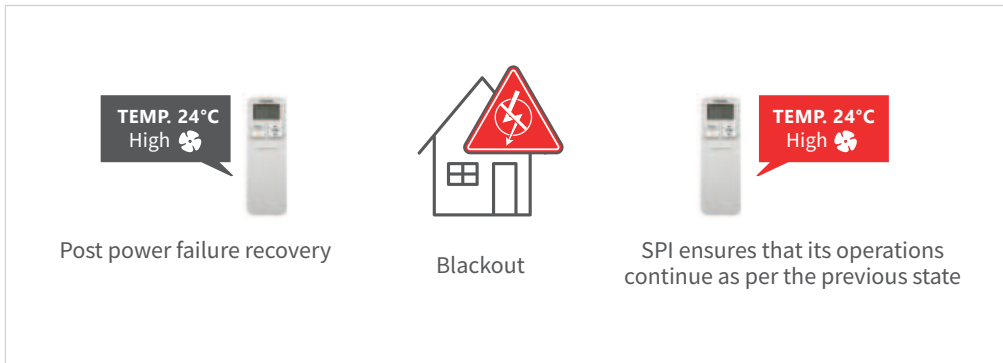

A modern living room interior featuring a vibrant red leather sofa with patterned and grey cushions. A tall green plant in a white pot stands near a large window with sheer curtains. The window looks out onto a balcony with a wooden railing and a view of misty mountains. A floor lamp with a white shade is visible on the right. The room has dark grey walls and a dark floor. The text 'The premier choice for Reliability & Technology' is overlaid in white at the bottom left.

The **premier** choice
for **Reliability & Technology**

Engineered with the latest technologies to deliver high reliability, Toshiba SPI Premier is built to be your efficient cooling partner.

► **Twin rotary compressor**

With a unique combination of a twin rotary compressor and an all inverter-driven control, this HVAC solution guarantees accuracy and expertise with exceptional Japanese quality.

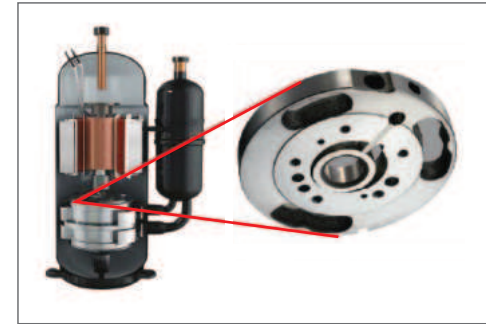

► **Plastic joint cover and rubber sheet installation**

Toshiba SPI Premier offers long-lasting operations due to the plastic joint cover and rubber sheet that is placed between the aluminium heat exchanger and steel part of the outdoor unit. This is specifically designed to reduce corrosion and enhance durability.

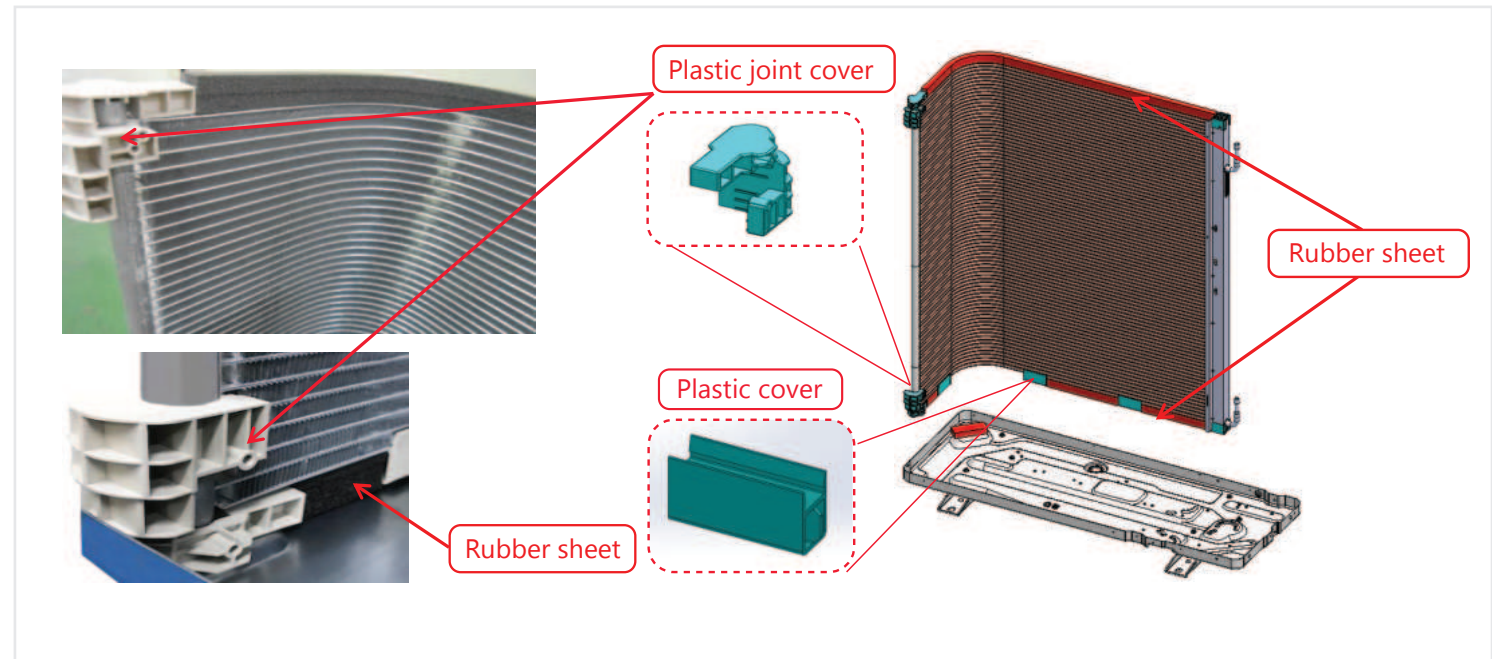

► **Protection circuit on board**

This HVAC solution is built with a protection circuit to safeguard the PC board in the case of unstable power supply.

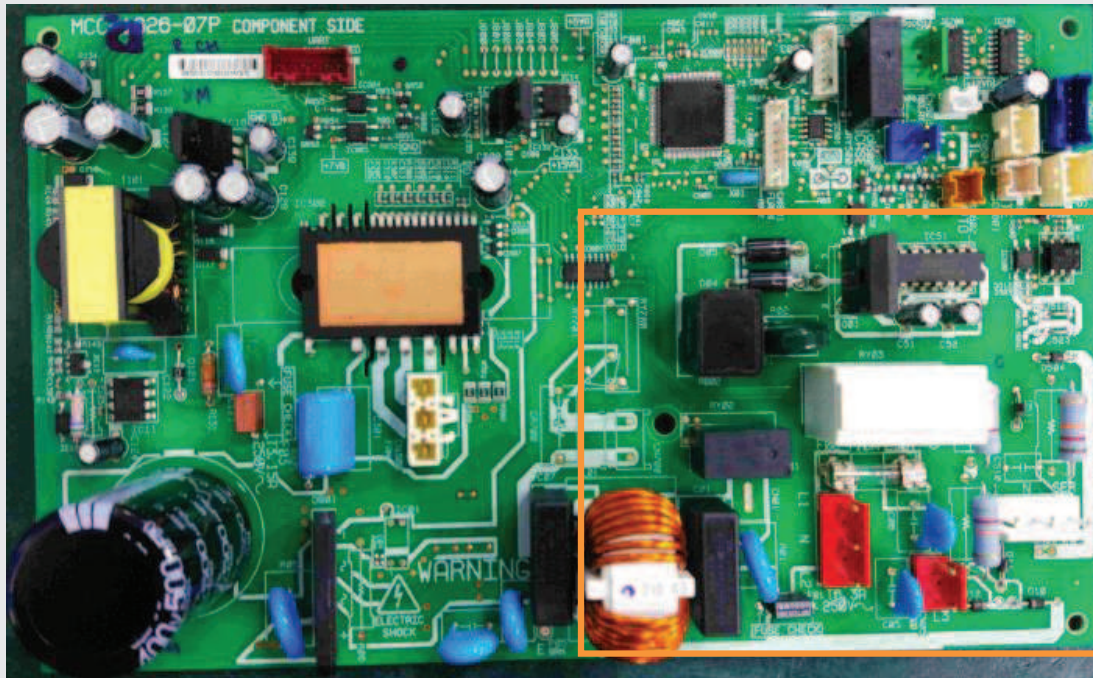

*Applicable for 3-phase products

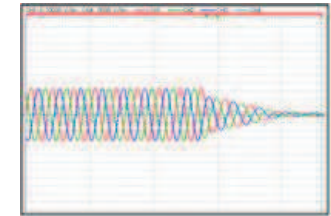

Blackout

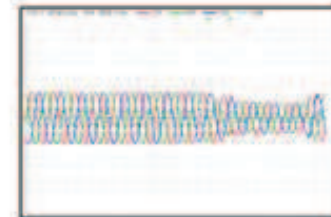

Temporary lower voltage

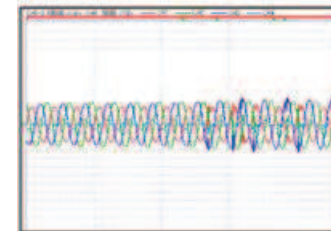

Unstable power supply

► Strainer in pipe system

Equipped with a strainer in the pipe system, Toshiba SPI Premier delivers reliable efficiency in removing dust and metal-abrasion powder.

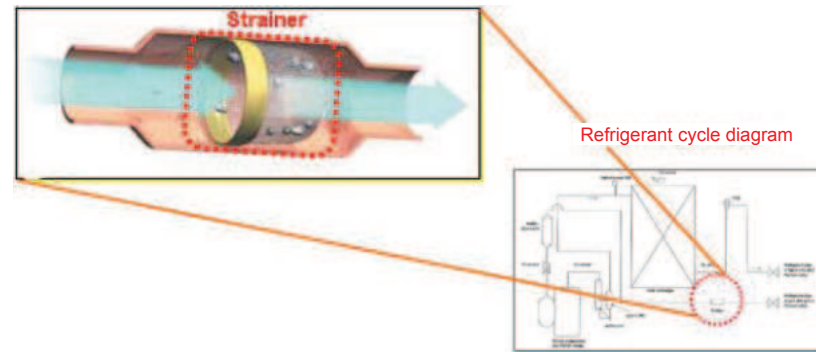





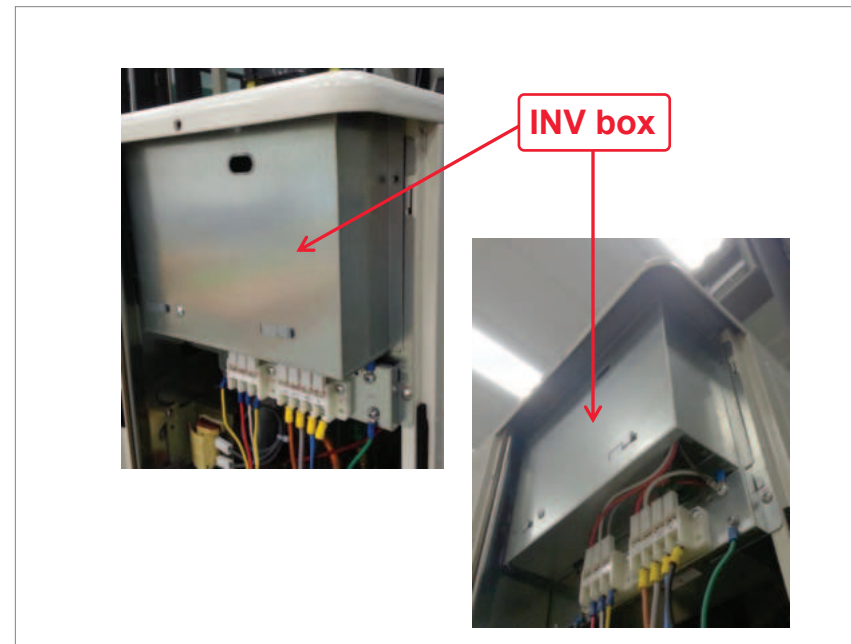
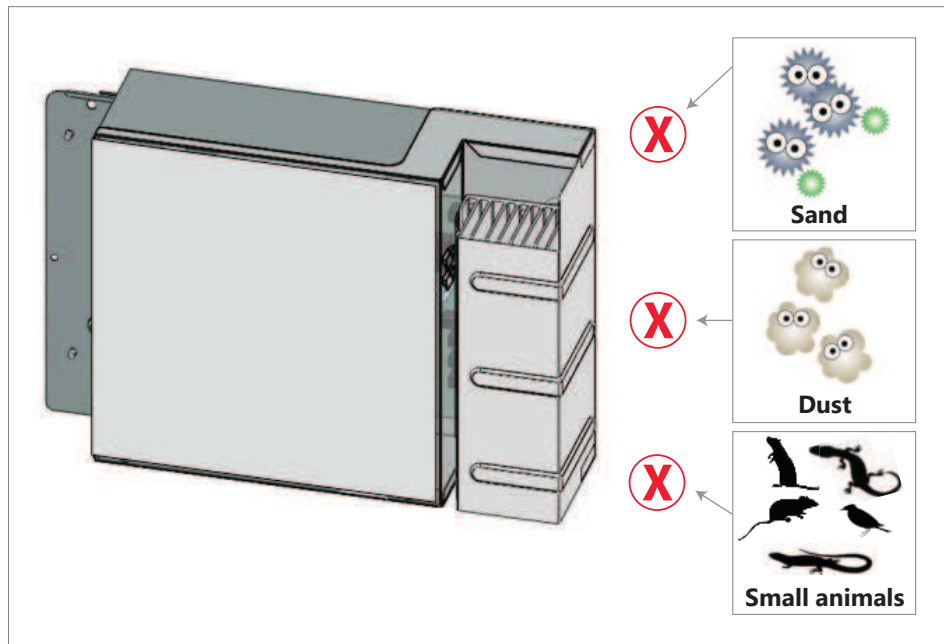







► Sealed inverter box

The HVAC unit is built for to thrive in Indian conditions. One of the features that enables this is the sealed-up inverter box that prevents any malfunctions due to contamination by sand, dust and small animals.



Toshiba SPI Premier

4-way cassette combination specification table

FCU model	RAV-GE1801UP-IN 	RAV-GE2401UP-IN 	RAV-GE3601UP-IN 	RAV-GE4201UP-IN 	RAV-GE4801UP-IN 	RAV-GE6001UP-IN 
CDU model	RAV-GE1801AP-IN 	RAV-GE2401AD-IN 	RAV-GE3601A8D-IN 	RAV-GE4201A8P-IN 	RAV-GE4801A8P-IN 	RAV-GE6001A8P-IN 
Capacity (HP)	2 HP	3 HP	4 HP	5 HP	6 HP	7 HP
Power Supply	1Ph 230V 50Hz			3Ph 400V 50Hz		
Cooling Capacity (kW)	5.3 (1.3 – 5.6)	6.9 (1.3 – 8.0)	10.6 (3.5 – 11.2)	12.3 (3.5 – 13.2)	14.1 (3.5 – 15.9)	18.1 (4.0 – 18.1)
Power Input (kW)	1.39	1.98	3.04	3.65	4.70	7.20
EER	3.81	3.48	3.49	3.37	3.00	2.51
ISEER	5.20 (5 Star)	5.11 (5 Star)	4.37 (5 Star)	4.42 (5 Star)	4.26 (5 Star)	NA
Indoor Unit H x W x D (mm)	256 x 840 x 840				319 x 840 x 840	
Indoor Unit Weight (kg)	20				24	
Indoor Unit Airflow (cmh)	1,050 / 870 / 780	1,230 / 960 / 810	1,800 / 1,530 / 1,230	1,860 / 1,530 / 1,230	2,130 / 1,500 / 1,260	2,200 / 1,820 / 1,500
Indoor Unit Sound Pressure Level (dB)	32 / 29 / 28	35 / 31 / 28	47 / 44 / 39	48 / 44 / 39	48 / 44 / 39	48 / 45 / 43
Outdoor Unit Dimension H x W x D (mm)	550 x 780 x 290			890 x 900 x 320		1,340 x 900 x 320
Outdoor Unit Weight (kg)	28	32	52	53	53	82
Outdoor Unit Sound Pressure Level (dB)	52	52	53	58	58	63
Max. Pipe H/L (m)	10 / 25		20 / 30		30 / 50	
Flare Pipe G/L (mm)	12.7 / 6.4		15.9 / 9.5		19.1 / 9.5	
Operating Range (°C)	15 ~ 46					

Note: Technical specifications are rated without the installation of PM 2.5 filter.

Panel to be purchased separately | Rated conditions: Indoor air temperature 27°C DB / 19°C WB; Outdoor air temperature 35°C DB

Star rating as per standards and labeling program of the Bureau of Energy Efficiency | Airflow is measured at high fan speed

Overview



The premier choice for Eco-Friendliness

- a. Lower GWP refrigerant use
- b. High ISEER value



The premier choice for Performance & Efficiency

- a. BEE 5-star rating
- b. 7 HP capacity



The premier choice for Clean Air

- a. PM 2.5 filter
- b. Acrylic resin-coated coil



The premier choice for Aesthetics

- a. Compact size
- b. Aesthetic 4-way cassette (new panel design)
- c. Choice of controllers



The premier choice for Comfort & Convenience

- a. 5-step airflow
- b. Auto restart function



The premier choice for Reliability & Technology

- a. Twin Rotary Compressor
- b. Strainer in pipe system
- c. Protection circuit on board
- d. Plastic joint cover and rubber sheet installation
- e. Sealed inverter box



Specifications: 4-way cassette combination



TOSHIBA SERVICE HELPLINE
1800 3000 3545
1800 1021 421

For more details, please contact our sales office:



Corporate & Registered Office: Carrier Airconditioning & Refrigeration Ltd, Kherki Daula Post, Narsingpur, Gurgaon 122004, Tel: 0124-4825500
Sales Offices:– **Ahmedabad:** 079-44820400/401 **Ghaziabad:** 0120-4183260 **Bangalore:** 080-43442000 **Bhubaneswar:** 9778030033 **Chandigarh:** 0172-5007549/50 **Chennai:** 044-66448888 **Cochin:** 0484-4029000/001, **Coimbatore:** 7397444250 **Daryaganj:** 011-23244491, 9810973264 **Delhi/NCR:** 0124-4873200 **Goa:** 9987868667 **Guwahati:** 9831079624 **Hyderabad:** 040-4181 2222 **Indore:** 0731-2445200 **Jaipur:** 0141-4921737 / 738 **Kolkata:** 033-40592000/3000 **Lucknow:** 0522-4158701/704 **Navi Mumbai/Thane:** 9167788252 **Mumbai:** 022-61700700 **Nagpur:** 9881714903 **Patna:** 7070621177 **Pune:** 020-48571000 **Raipur:** 9752542882 **Surat:** 7433920332

March 2024

CIN: U74999HR1992FLC036104

Website: www.toshibaac.in

E-mail: info@toshibaac.in

TOSHIBA

This catalogue provides certain general information and is intended for general guidance only and Carrier is not liable for any damage arising out of the use of the catalogue. The Manufacturer reserves the right to change any product specification without prior notice.

All Proprietary Rights Reserved by Carrier.